

## DH-100-A - ANALOG DUCT DETECTOR

*Smoke port for testing without cover removal*

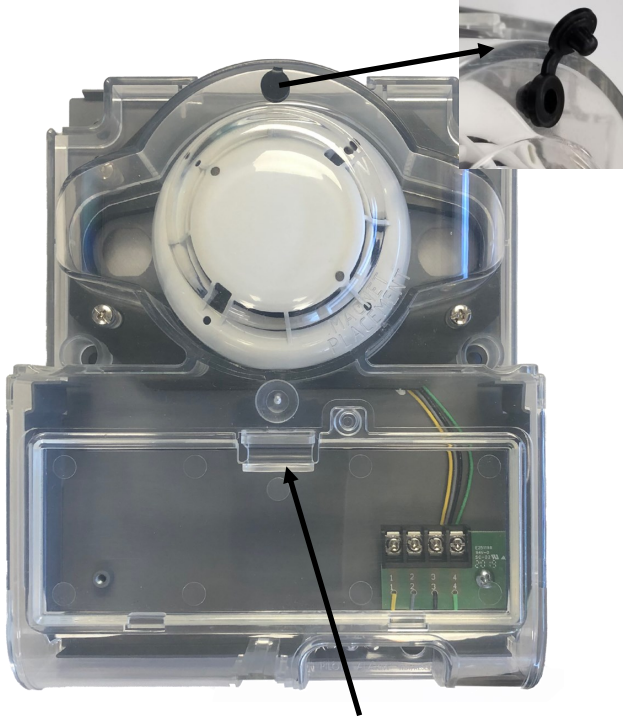

*Wiring Access hatch for wiring maintenance without cover removal*

### SPECIFICATIONS

<b>Duct Detector Model #</b>	DH-100-A
<b>Detector Head Model</b>	ALN-DH
<b>Detector Head Type</b>	Analog Photoelectric
<b>Communication</b>	DCP Powered Loop
<b>Standby Current</b>	450µA
<b>Alarm Current</b>	30mA (max)
<b>Sensitivity Test Method</b>	Smoke Port
<b>Air Velocity</b>	100 to 4000 ft/min.
<b>Ambient Temperature</b>	32°F to 100°F (0°C to 38°C)
<b>Humidity</b>	10% to 93% Relative Humidity (non-condensing)
<b>Housing Material</b>	18 G.A. steel backbox, clear plastic cover
<b>Finish</b>	Grey Powder Coat Enamel
<b>Dimensions</b>	9 1/8" L x 7 1/4" W x 2 1/4" H
<b>Maximum Net Weight</b>	3lbs.
<b>Sampling Tubes</b>	2.5ft. Model: STS-2.5 P/N: 0400-01580 5ft. Model: STS-5.0 P/N: 0400-01590 10ft. Model: STS-10.0 P/N: 0400-01570

*Specifications subject to change without notice.*

### STANDARD FEATURES

- Air Low Flow 100FPM Listed
- Detects and limits the spread of smoke throughout building HVAC ducts
- Compatible with building automation and fire alarm systems
- Installs quickly and easily
- No screens or filters to clean
- Rugged gray steel back box with clear cover
- Accessories - Remote LED alarm indication capability
- UL 268A Listed

### APPLICATION

The HOCHIKI AMERICA DH-100-A Analog duct smoke detector provides early detection of smoke and products of combustion present in air moving through HVAC ducts in Commercial, Industrial and Residential applications. The DH-100-A is designed to prevent the recirculation of smoke in areas by the air handling systems, fans and blowers. Complete systems may be shut down in the event of smoke detection. The HOCHIKI AMERICA DH-100-A operates on a DCP powered loop.

### PRODUCT DESCRIPTION

The DH-100-A is designed and built to meet all local requirements, as well as the NFPA regulations regarding duct smoke detectors. The DH-100-A is provided with output terminals for remote status indicators. Air sampling is accomplished by two tubes which protrude into the duct. An exhaust tube of on standard length (7.5") is supplied in the installation kit with the smoke duct unit. Once the duct width has been determined the air intake sampling tubes must be ordered. Sampling tubes are supplied in three standard lengths 2.5ft., 5 ft. and 10ft. and cut to size to fit the duct.

#### PRODUCT LISTINGS



California State  
Fire Marshal  
3240-0410:0155

## DH-100-A - ANALOG DUCT DETECTOR

### ELECTRICAL INSTALLATION

#### A. GENERAL INFORMATION

Wiring must conform to applicable local codes, ordinances and regulations covering these types of devices. Wire the detectors according to the engineering drawings for the particular job requirements. These detectors are not intended for open area protection, nor should they be used for open air protection. Refer to NFPA 90A and NFPA 72 for general and additional information on Duct Smoke Detectors concerning operation and installation. Terminals are suitable for up to #14 gauge wire.

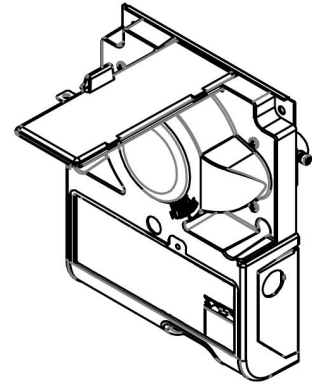

*DH-100-A Access Hatch Cover Temporary Storage*

#### B. DETECTOR WIRING

With power source de-energized, wire all connections. The wiring access hatch cover can be stored at the top of the unit. Return cover before restoring power.

#### C. TERMINAL BOARD WIRING

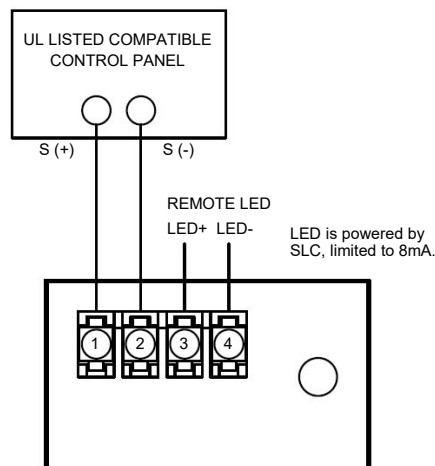

### SPECIFICATIONS

<b>SLC Applied Voltage</b>	Rated Range 25.3 - 39.5 VDC
<b>SLC Current Consumption</b> (includes detector)	Alarm            30mA Max Normal Standby   450µA
<b>Operating Temperature Range</b>	0°C (32°F) ~ 38°C (100°F)
<b>Storage Temperature Range</b>	-30°C (22°F) ~ 70°C (158°F)
<b>Maximum Relative Humidity</b>	93% RH non-condensing
<b>Air Velocity</b>	100 - 4,000 FPM
<b>Sensitivity</b>	0.70 - 3.74% / FT @ 100 FPM 0.70 - 3.38% / FT @ 300 FPM 0.70 - 3.39% / FT @ 1000 FPM 0.70 - 3.83% / FT @ 2000 FPM 0.70 - 4.00% / FT @ 3000 FPM 0.70 - 4.00% / FT @ 4000 FPM
<b>Environment</b>	Indoor dry use only, Duct Side or Top
<b>Dimensions</b>	7.5"W X 9.5"H X 2.5"D
<b>Weight</b>	Approximately 3.0lb